

KEY FEATURES

- 1" exit (25,4 mm) high frequency compression driver
- 1" (25,4 mm) voice coil diameter
- 60 W program power above 2,5 kHz
- Sensitivity: 106 dB (1W / 1m)
- PM-4 polymer diaphragm
- Ultra lightweight edgewound aluminium voice coil
- Cover with standard 1" 3/8 thread

TECHNICAL SPECIFICATIONS

Throat diameter	25,4 mm	1 in
Rated impedance		8 Ω
Minimum impedance	8,3 Ω @ 7 kHz	
D.C. resistance		5,4 Ω
Power capacity*	30 W _{AES} above 2,5 kHz	
Program power	60 W above 2,5 kHz	
Sensitivity**	106 dB 1W / 1m @ Z _N coupled to TD-2012/N	
Frequency range		2 - 20 kHz
Recommended crossover	2,5 kHz or higher (12 dB/oct min.)	
Voice coil diameter	25,4 mm	1 in
Flux density		1,5 T
BI factor		4,6 N/A

MOUNTING INFORMATION

Overall diameter	73 mm	2,87 in
Depth	65 mm	2,56 in
Mounting		1" 3/8 thread
Net weight	0,6 kg	1,32 lb
Shipping weight	0,7 kg	1,54 lb

Notes:

* The power capacity is determined according to AES2-1984 (r2003) standard. Program power is defined as the transducer's ability to handle normal music program material.

** Sensitivity was measured at 1m distance, on axis, with 1W input, averaged in the range 2 - 10 kHz.



DIMENSION DRAWINGS

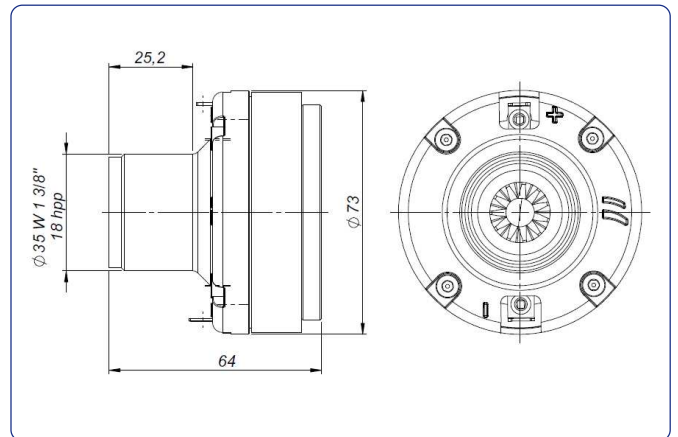

FREE AIR IMPEDANCE CURVE

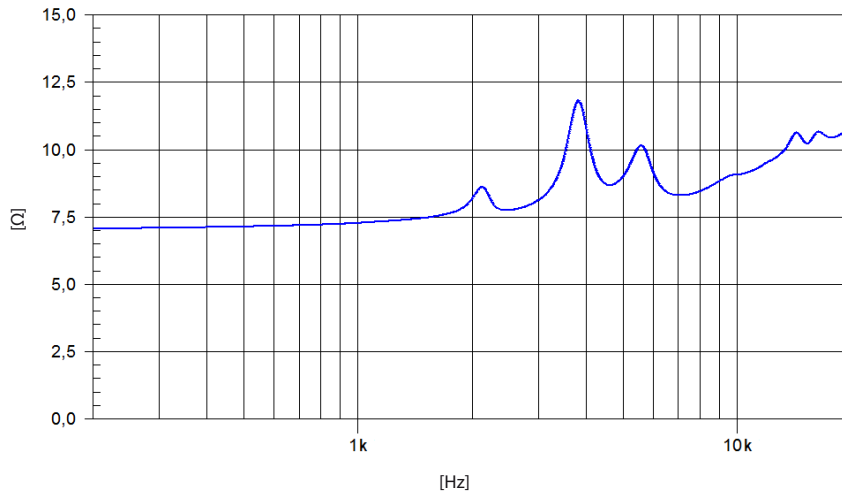

FREQUENCY RESPONSE CURVE

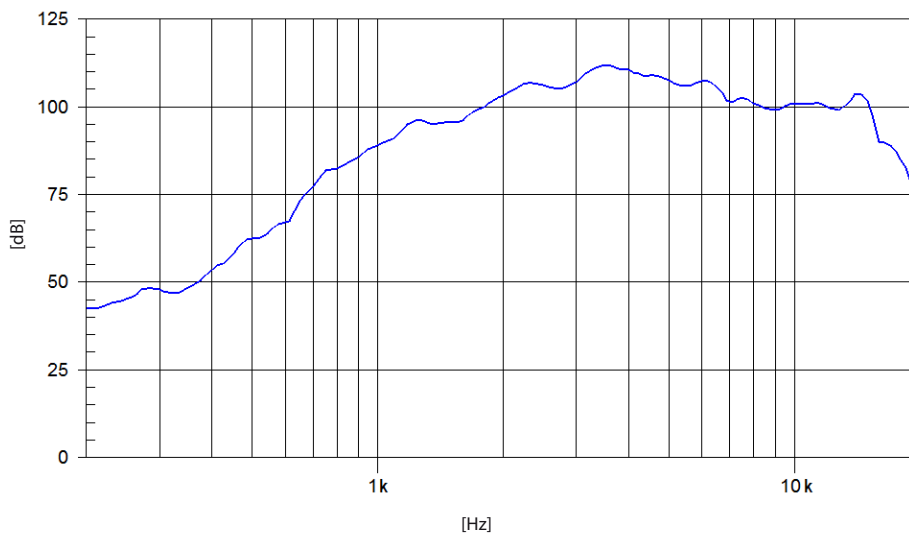

Note: On axis frequency response measured couplead to TD-2012/N horn in anechoic chamber, 1W / 1m